

NPS	L	D	D1	D2	C	f	n- ϕ b	Weight (lb)
1/2"	5.118	3.543	2.374	1.374	0.394	0.063	4- ϕ 0.630	5.512
3/4"	5.512	3.937	2.752	1.698	0.433	0.063	4- ϕ 0.630	6.614
1"	5.906	4.331	3.126	2.000	0.472	0.063	4- ϕ 0.630	7.716
1 1/4"	6.693	4.528	3.500	2.500	0.512	0.063	4- ϕ 0.630	11.023
1 1/2"	7.874	4.921	3.874	2.874	0.591	0.063	4- ϕ 0.630	14.330
2"	8.661	5.906	4.752	3.626	0.630	0.063	4- ϕ 0.748	16.535
2 1/2"	9.921	7.087	5.500	4.126	0.709	0.063	4- ϕ 0.748	25.353
3"	11.024	7.480	6.000	5.000	0.748	0.063	4- ϕ 0.748	29.762
4"	12.598	9.055	7.500	6.189	0.945	0.063	8- ϕ 0.748	47.399
5"	13.780	10.039	8.500	7.311	0.945	0.063	8- ϕ 0.866	46.218
6"	15.748	11.024	9.500	8.500	1.024	0.063	8- ϕ 0.866	68.343
8"	19.094	13.583	11.752	10.626	1.142	0.063	8- ϕ 0.866	141.096

NOTE:

- 1.Design and Manufacture for valve according to ANSI B16.34-2009.
- 2.End flange dimensions for valve according to ASME B16.5-2009.
3. Inspection and Test for valve according to API 598-2009.

NO.	DESCRIPTION	Q' TY	MATERIAL
7	NUT	-	A194 8
6	STUD	-	A193 B8
5	PLUG	1	A351 CF8M
4	BONNET	1	A351 CF8M
3	GASKET	1	SS316+Graphite
2	BASKET	1	SS316
1	BODY	1	A351 CF8M

MARK	BEFORE MODIFIED	AFTER MODIFIED	DATE	 DISCOUNT VALVES	Flanged Y-Strainer 150LB, CF8M	
DRA.		APP.				
CHK.		DATE			SCALE	

WWW.DISCOUNTVALVES.COM

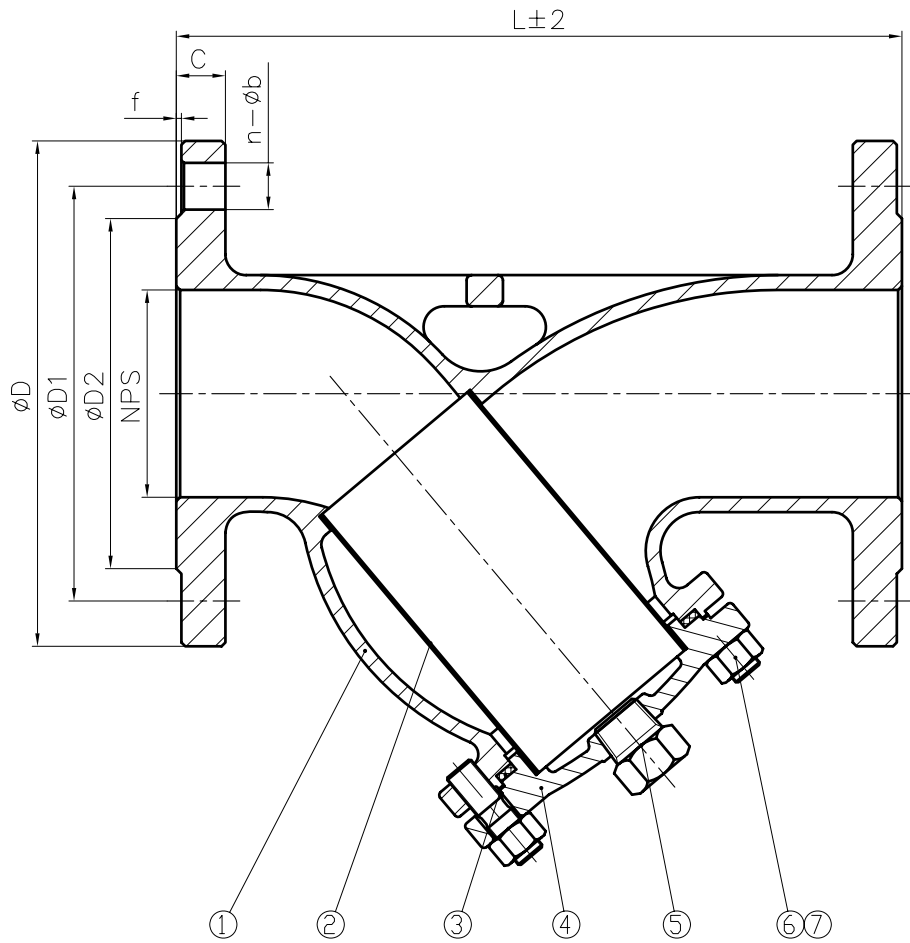

Nominal pressure		150LB					
Test pressure	Shell test	3.0	MPa	test medium	water	Test temperature	normal temperature
	Gas seal test	0.6		air			
Applicable medium		water,oil,gas					
Applicable temperature		-20~797°F					

