

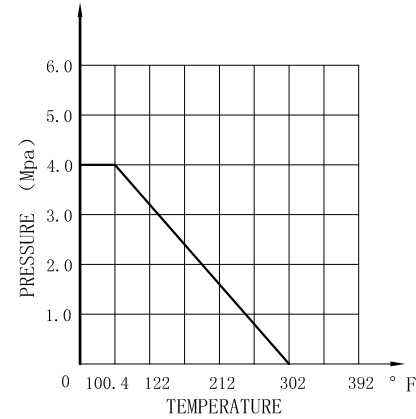

Nominal pressure			4.0Mpa				
Test pressure	Shell test	6.0	Mpa	Test medium	Water	Test temperature	Normal temperature
	Seal test	4.4			Air		
	Gas seal test	0.6					
Applicable medium			Water,Oil,Gas				
Applicable temperature			-20~302°F				

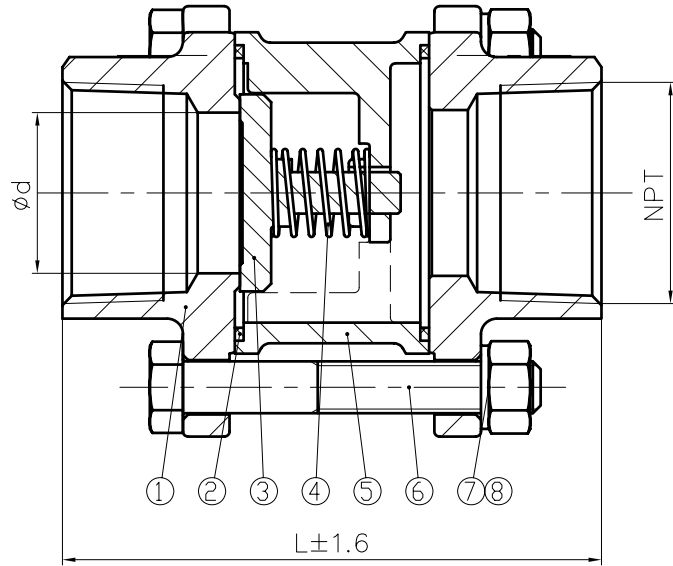

NOTE:

- 1.Design and Manufacture for valve according to ASME B16.34.
- 2.Inspection and Test for valve according to API 598.
- 3.The connection of screwed for valve according to ANSI B1.20.1.

NPS	L	d	NPT	Weight (lb)
¼"	2.953	0.433	¼"	0.882
⅜"	2.953	0.433	⅜"	0.882
½"	2.953	0.551	½"	0.882
¾"	3.150	0.748	¾"	1.058
1"	3.386	0.945	1"	1.378
1 ¼"	4.094	1.220	1 ¼"	1.918
1 ½"	4.528	1.535	1 ½"	3.395
2"	4.803	1.929	2"	4.861

8	NUT	-	A194 8
7	SPRING WASHER	-	304
6	HEXAGON HEAD BOLT	-	A193 B8
5	BODY	1	A351 CF8M
4	SPRING	1	SS316
3	DISC	1	A351 CF8M
2	GASKET	2	PTFE
1	BONNET	2	A351 CF8M
NO.	DESCRIPTION	Q' TY	MATERIAL
			 DISCOUNT VALVES
			3PC Chevk Valve PN40, NPT
MARK	BEFORE MODIFIED	AFTER MODIFIED	DATE
DRA.		APP.	
CHK.		DATE	
			SCALE
			WWW.DISCOUNTVALVES.COM